

GRAB-EEZ™

Cleanroom Wipe Dispenser

Assembly Instructions

Parts list:

1. Dispenser Box
2. Base Stand
3. Screws
4. Pivot Pin
5. Front Cover
6. Wipe Stack (sold separately)
7. Weight

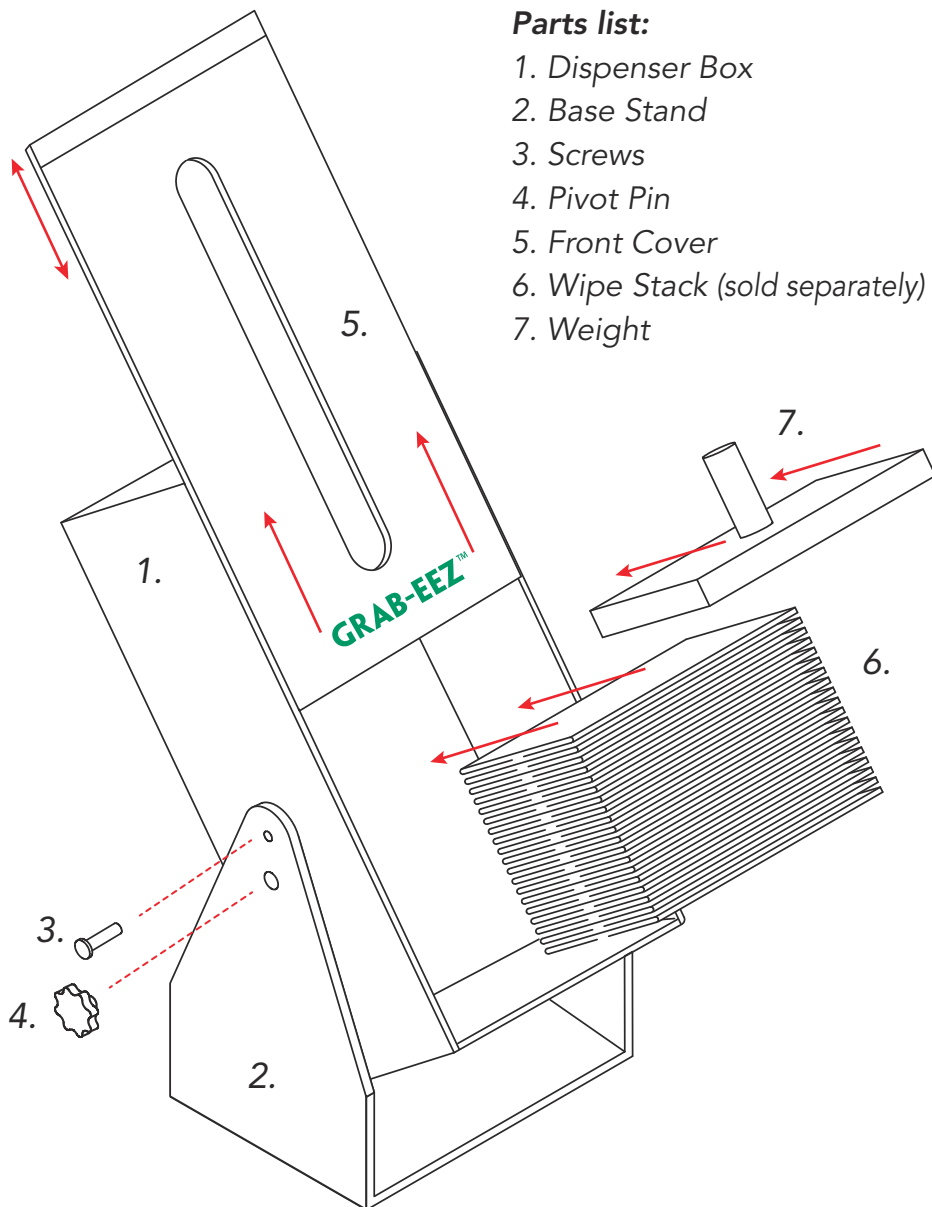

Assembly for table top use

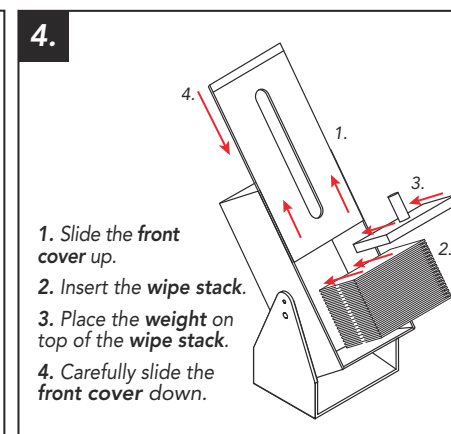
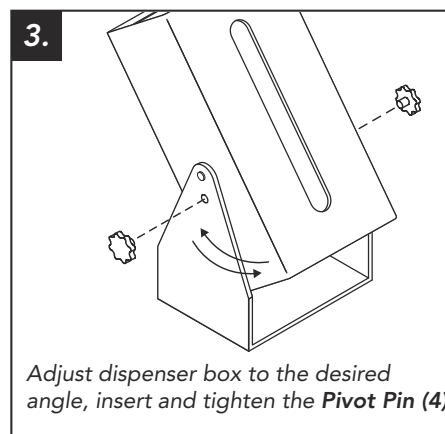
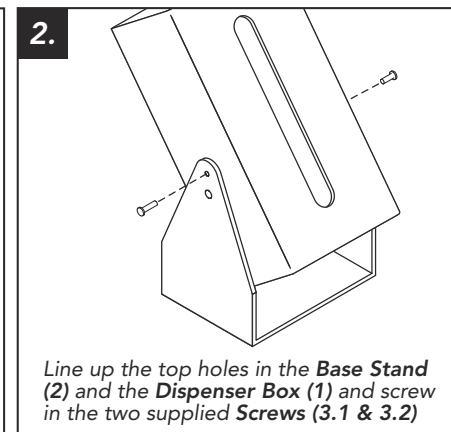
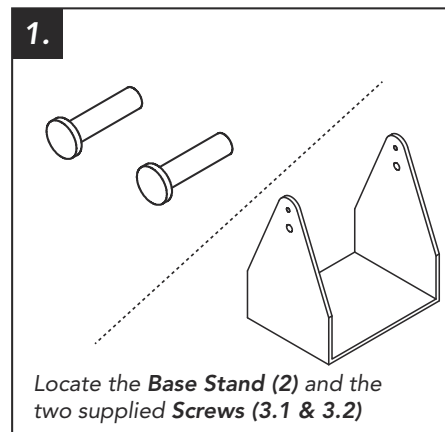

*Carefully place the weight and slide down the front cover to avoid damage to base

Assembly for wall mounting

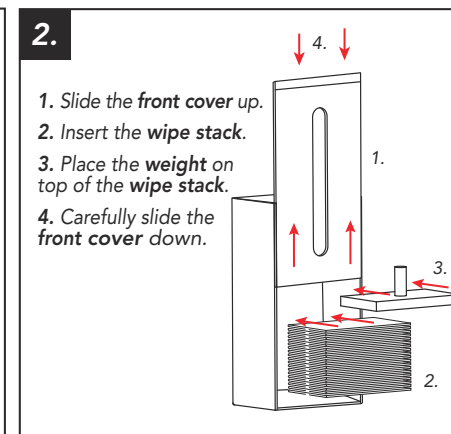
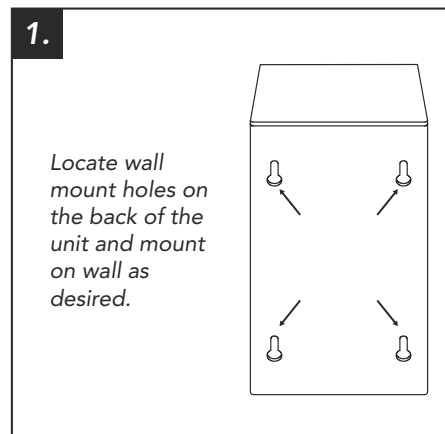

*Carefully place the weight and slide down the front cover to avoid damage to base

GRAB-EEZ™

Cleanroom Wipe Dispenser

Dimensions

